



FOR MORE INFORMATION, CALL 1-800-922-MACK OR VISIT [WWW.MACKTRUCKS.COM](http://WWW.MACKTRUCKS.COM)

©2006 Mack Trucks, Inc. All rights reserved. Mack, Mack and the Bulldog design, Bulldog Protection Plan, Econodyne, MaxiCruise, Granite, Maxidyne and V-MAC are registered trademarks; DataMax, GuardDog, MackCap, MP, Pinnacle and PowerLeash are trademarks of Mack Trucks, Inc.

The information in this brochure was accurate at the date of publication. Mack Trucks, Inc. reserves the right to make changes in specifications, equipment or design, or to discontinue certain models or options without notice at any time. Warranty terms and services may vary in certain countries. Some of the equipment shown or described in this brochure is available at extra cost through retail organizations and establishments not associated with Mack Trucks, Inc.

1B-MPE-08/06-SWBR/20M

MACK MP ENGINE SERIES — MP7 & MP8

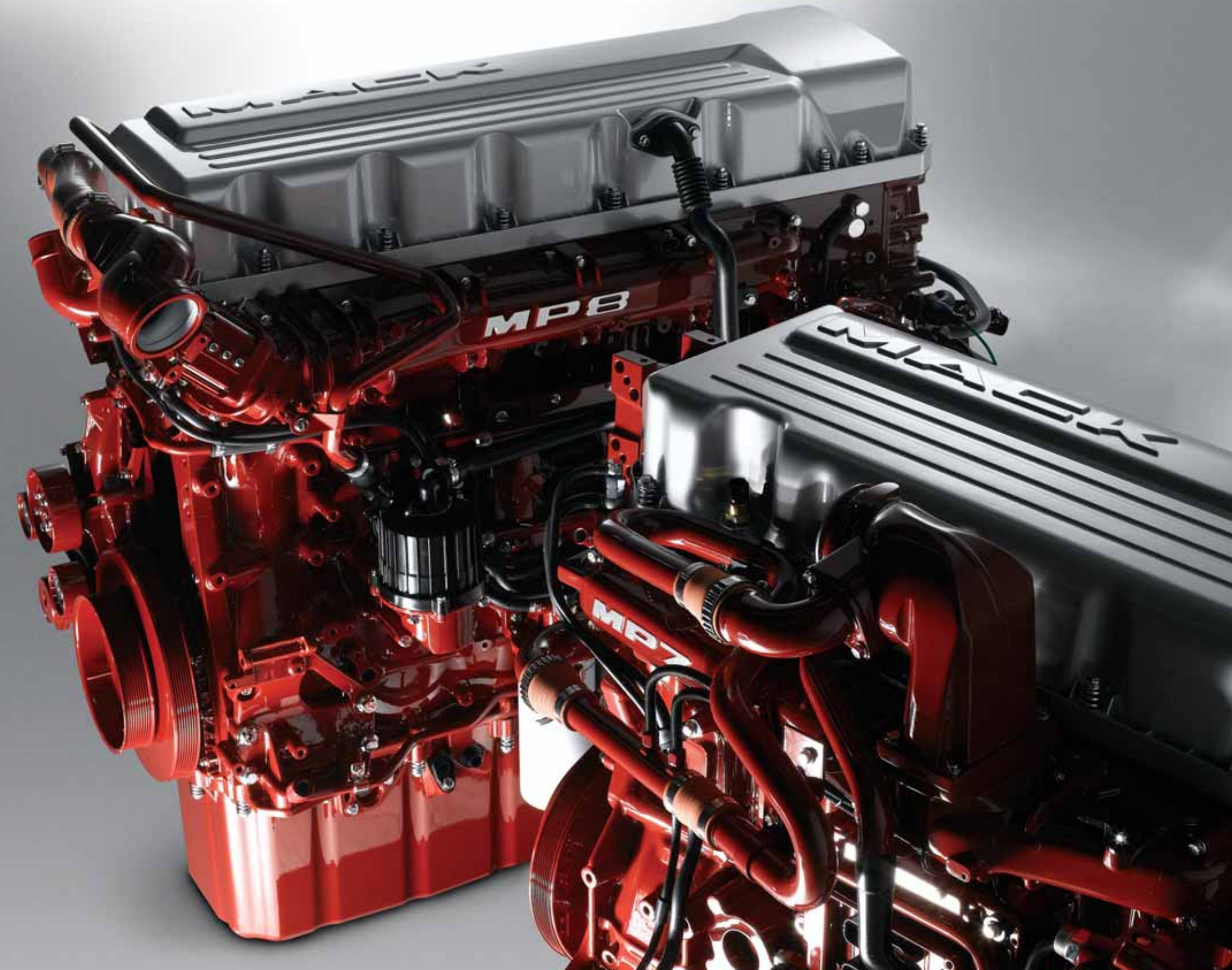

# ENGINES

## BLOWING AWAY THE COMPETITION.

The all-new MP7 and MP8 engines, the latest members of the Mack® MP™ Engine Series, draw on proven technology to boost power and run cleaner. These engines meet the strict emissions requirements of the EPA for 2007. Engineered with the power, torque and durability you have come to expect from the industry's leader in integrated powertrains, the MP7 and MP8 engines are versatile enough to cover all highway and vocational applications.

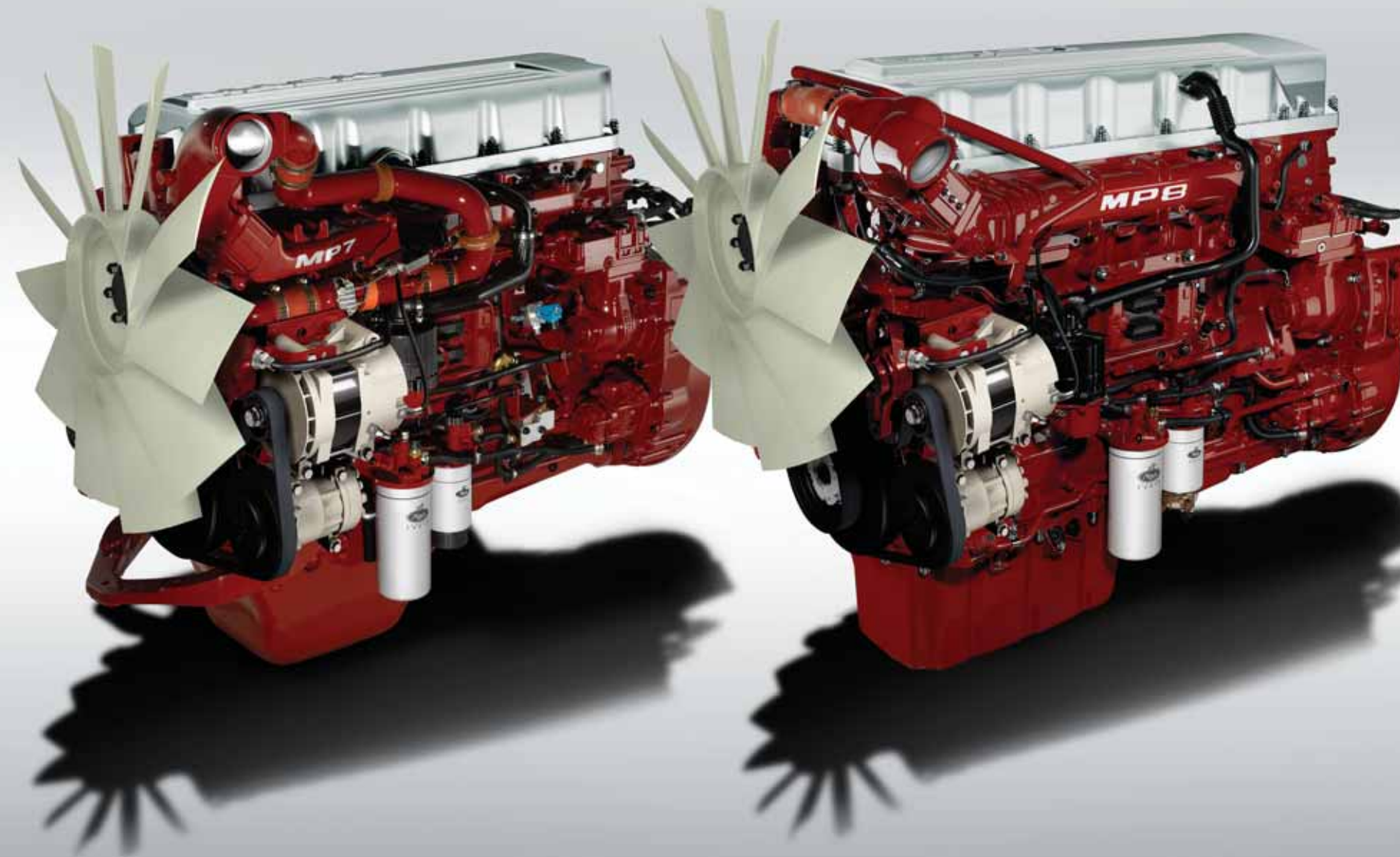

## MP7 and MP8 ENGINE SERIES

### A POWERFUL ADDITION TO THE FAMILY.

The MP8 engine has the highest horsepower with the lowest emissions ever offered by Mack. The 13-liter MP8 has a horsepower range from 415 HP to 485 HP and torque levels from 1,540–1,700 lb.-ft. The 11-liter MP7 engine possesses a horsepower range from 325 HP to 405 HP and torque ratings from 1,200–1,560 lb.-ft.

### MINOR ADJUSTMENTS MAKE MAJOR IMPROVEMENTS.

The new MP7 and MP8 engines boast a few improvements from their predecessor, the US'04-compliant MP7. The most significant is the redesigned Exhaust Gas Recirculation (EGR) Cooler, which now utilizes a tube-and-insert configuration for even more efficient cooling. These engines deliver the same performance and reliability of the previous MP7, which has been road-tested and respected by drivers for more than two years.

### MEETING THE MACK STANDARD.

Engineered to perform to legendary standards, these new MP engines live up to the indisputable reputation of durability and dependability that Mack has delivered on for more than a century. These state-of-the-art engines feature single overhead cams and ultra-high-pressure fuel injection. The electronically controlled Variable Geometry Turbocharger incorporates the latest technology to cool both the turbo and actuator. It is designed with fewer parts, has one-piece steel pistons, and stronger bearings and cylinder heads, giving operators a powerplant built to last.



### LOG MORE MILES WITH LESS STOPS.

These new engines remain true to the MP Engine Series, which was introduced with improvements to the injection and air management system to achieve better fuel economy. Fuel economy is expected to increase by approximately 3 percent for highway and 6 percent for vocational use.

### AN ENGINE BRAKE POWERFUL ENOUGH TO STOP A MACK.

Mack's engine brake, PowerLeash™, is ideal for operation in the new MP7 and MP8 engines. It is every bit as durable, powerful and reliable as a Mack truck itself. It provides more braking horsepower through mid-RPM ranges, and weighs less than other engine brakes.

### POUND-FOR-POUND, THESE ENGINES DELIVER.

All the power you need, without an ounce of additional weight. The 11-liter MP7 engine is a lightweight and compact package. It is 37 pounds lighter than previous Mack vocational engines and 153 pounds lighter than previous Mack highway engines.

### ENGINEERED FOR ULTRA LOW SULFUR DIESEL (ULSD).

The all-new MP7 and MP8 engines have been designed, developed and tested using ULSD, which uses only 15 ppm (parts per million) sulfur. These engines will not meet the emission standards using pre-2007, 500 ppm diesel fuel. The ULSD fuel must be used in all US'07-compliant engines that use a catalyzed DPF or the catalyst will be poisoned. Improper fueling will reduce its effectiveness for regeneration and potentially require more frequent filter service or replacement of the catalyst. Any emission control system component damage due to improper fueling will not be covered under the Mack engine warranty.

### ULTIMATE PERFORMANCE.

The new MP7 and MP8 engines are designed to maximize the many great benefits and features of each Mack truck. Each engine comes in the same three families (Maxidyne®, MaxiCruise® and Econodyne®) to optimize performance in a wider operating range. Maxidyne provides power for high-performance, severe-duty conditions, especially in off-road applications. MaxiCruise provides performance for rolling interstate and on and on-off applications. Econodyne is ideal for typical interstate and part load/part throttle applications where fuel economy is the priority.

### SEAMLESS INTEGRATION.

Each new MP7 and MP8 engine will match current transmission offerings. The vocational-preferred Maxidyne engine family works with the Mack T300, TM300, vendor manual and full-automatic transmissions. The MaxiCruise engine family, which is ideal for highway and vocational use, utilizes the Mack T300, vendor manual, automated manual and full-automatic transmissions. And the Econodyne engine family works best for highway applications using the Mack T300, vendor manual and automated manual transmissions.

MAXIDYNE®		MAXICRUISE®		ECONODYNE®	
ENGINE	HP	ENGINE	HP	ENGINE	HP
MP7	325M	MP7	345C	MP7	325E
MP7	365M	MP7	365C	MP7	355E
MP7	405M	MP7	395C	MP7	405E
MP8	425M	MP8	415C	MP8	425E
MP8	455M	MP8	445C	MP8	455E
MP8	485M	MP8	485C	MP8	485E
ENGINE TORQUE LEVELS MP7: 1,200–1,420 lb.-ft. MP8: 1,540–1,700 lb.-ft.		ENGINE TORQUE LEVELS MP7: 1,350–1,560 lb.-ft. MP8: 1,540–1,660 lb.-ft.		ENGINE TORQUE LEVELS MP7: 1,260–1,460 lb.-ft. MP8: 1,560–1,660 lb.-ft.	

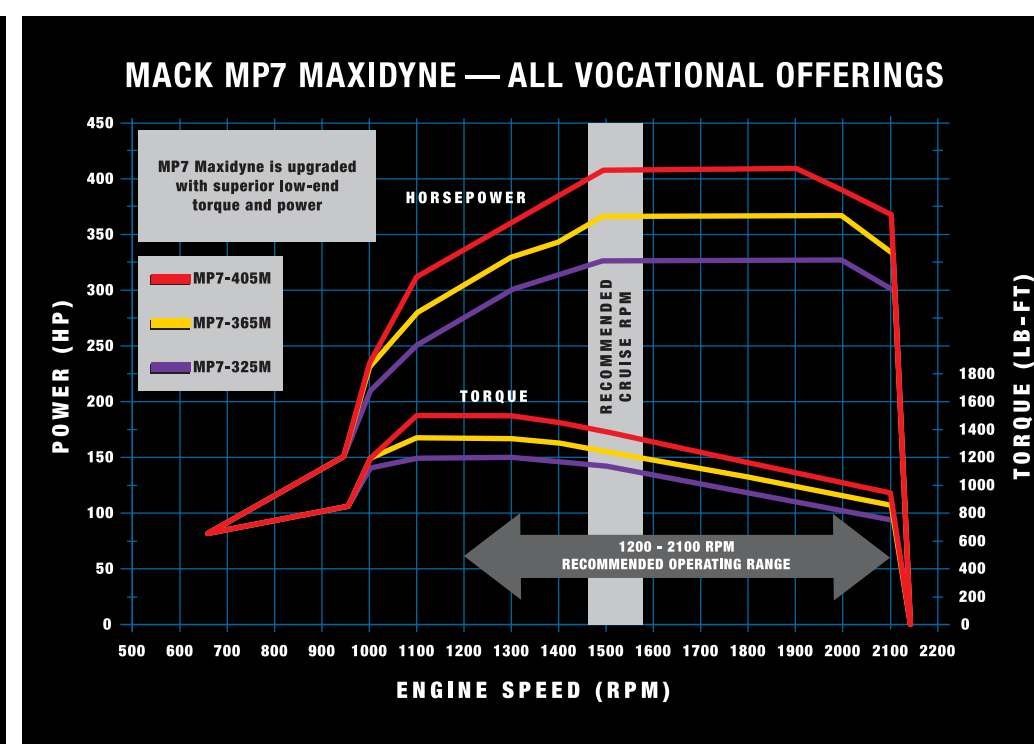
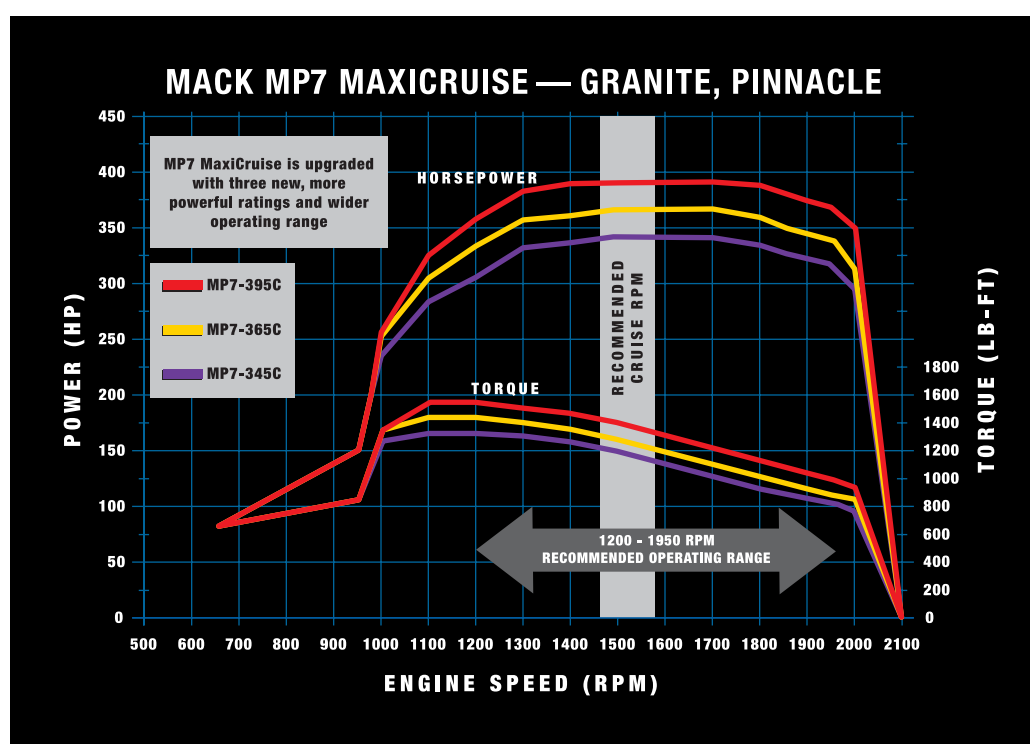
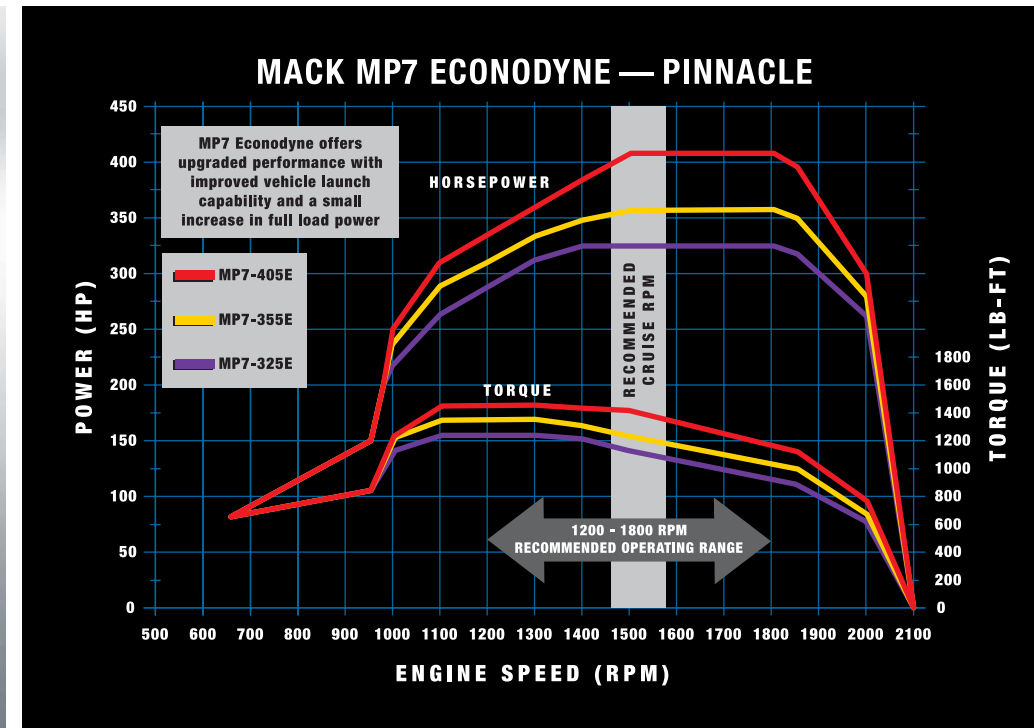

**THE PATH TO PROFITABILITY.**

Mack electronics deliver the technology you need, so drivers and managers can boost productivity. The new Granite® MP Engine Series and Mack Pinnacle™ MP Engine Series use our time-tested and road-proven Vehicle Management and Control System or V-MAC® IV. This next generation of advanced electronics gives you greater control of your costs and lets you monitor your truck and engine better than ever. In addition to hundreds of proven programmable features, V-MAC IV adds a host of new items, from the simple yet smart design of the daytime running light override, to the comprehensive ABS-based tamper detection. V-MAC IV comes with DataMax™, an advanced trip recorder that captures vehicle trip histories, duty cycle information and scheduled maintenance intervals.

**THE ULTIMATE WATCHDOG.**

The GuardDog™ preventative maintenance monitor is one of the best weapons you have to combat unplanned downtime. Maintenance data comes from real-time sensors instead of preprogrammed schedules based on mileage. As a result, accurate information reduces downtime and boosts efficiencies based on your operation.

**TOP-NOTCH PROTECTION.**

The base warranty as provided is 3 years/300,000 miles on the MP7 and MP8 engines. Extended Bulldog Protection Plans® can be tailored to meet your needs.

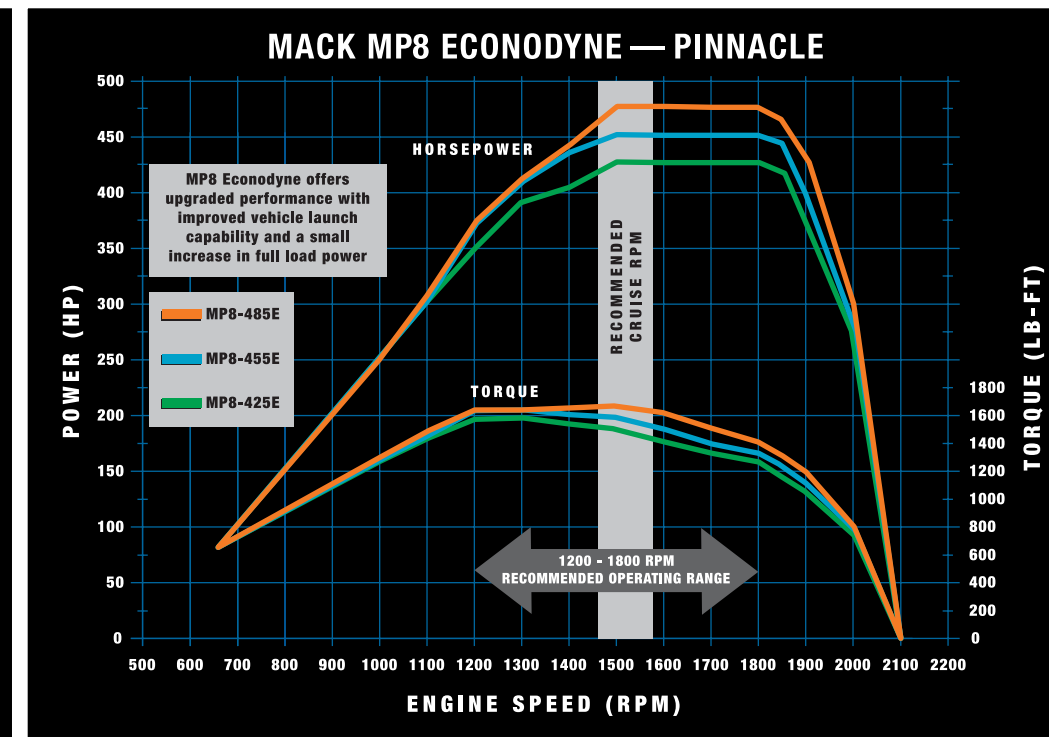
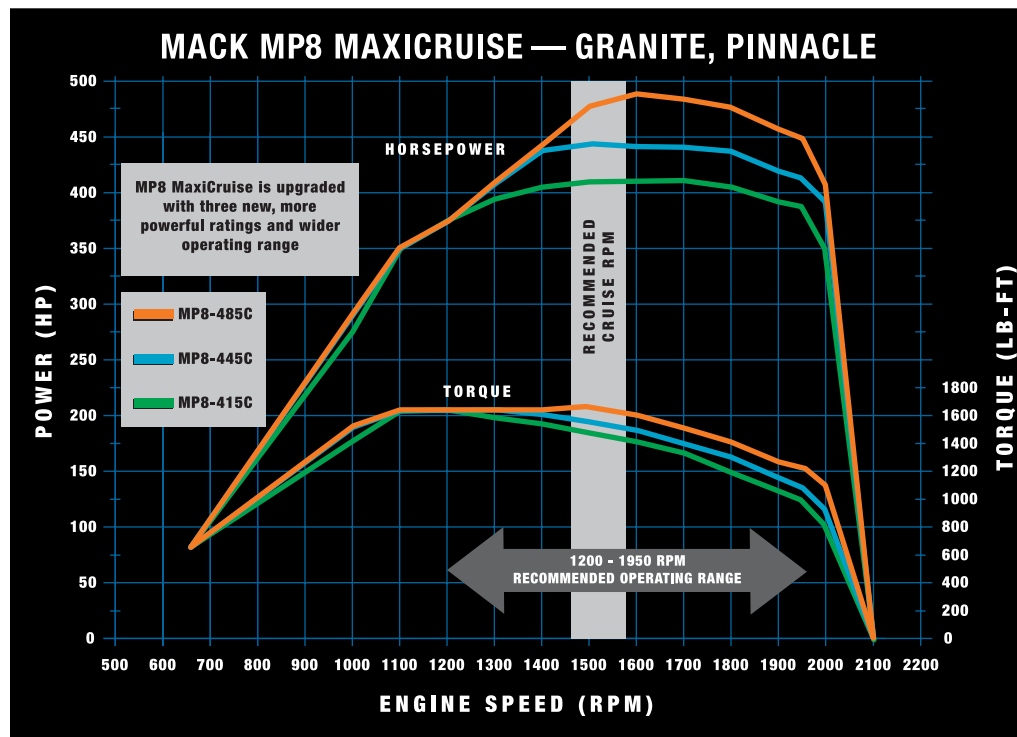
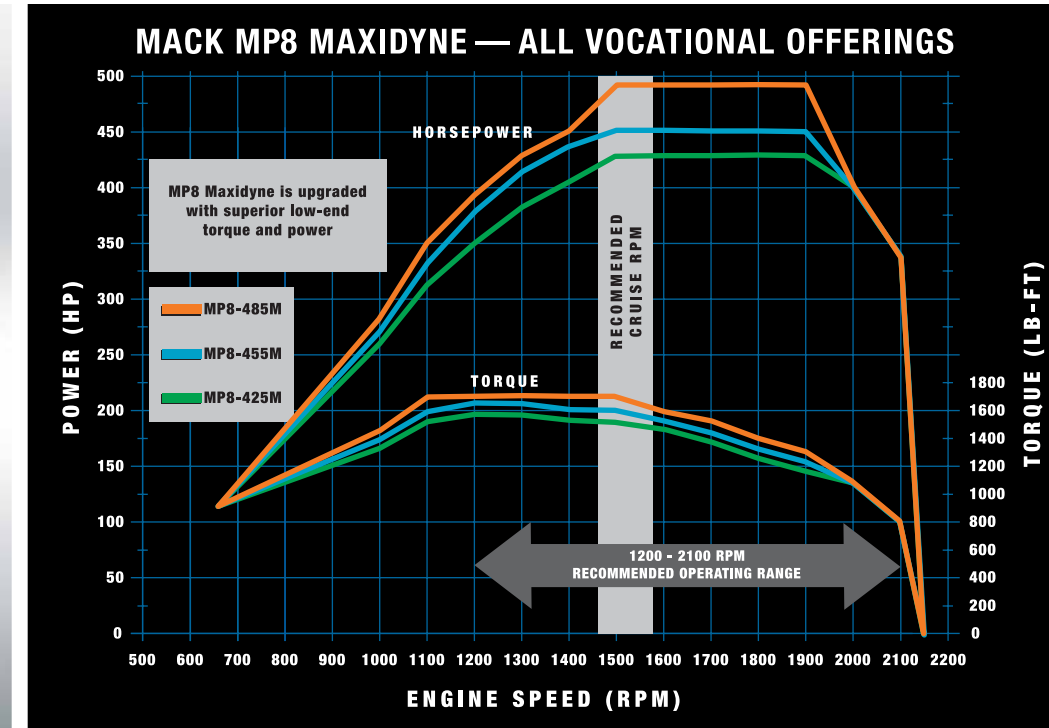



Mack Back-of-Cab DPF



MackCap DPF

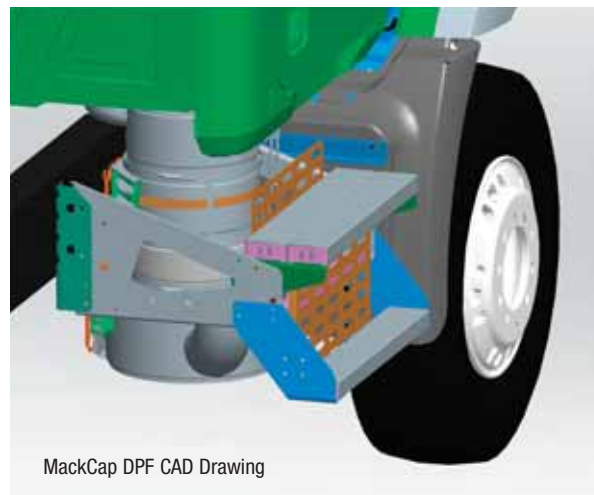

MackCap DPF CAD Drawing



MackCap DPF

## DIESEL PARTICULATE FILTERS

### CLEAN LIVIN'.

As one of the industry's vertically integrated manufacturers that designs and builds its own trucks and engines, we were able to seamlessly incorporate Diesel Particulate Filters (DPF) into our exhaust system, producing cleaner running trucks without sacrificing any benefits of the MP Engine Platform. Mack has engineered a technically savvy solution that is commercially viable for US'07.

### DESIGNED TO FIT YOUR NEEDS.

The DPF is designed in three unique configurations: Mack Back-of-Cab Catalyzed and Non-Catalyzed DPFs, and a compact MackCap™ Catalyzed DPF to fit the needs of each truck. In a catalyzed DPF, a small amount of fuel is injected upstream in the exhaust. This fuel does not combust. The regeneration is a chemical reaction between the platinum-coated catalyst in the DPF and the fuel hydrocarbons which raises the temperature within the filter high enough to oxidize the soot collected in the filter. In a non-catalyzed DPF, a thermal regenerator is used to elevate the temperature within the filter to oxidize the soot. Active regeneration only takes place when the engine is creating sufficient passive heat. The DPF reduces particulate matter (PM) emissions by more than 90 percent from US'04 levels.

### MAINTENANCE IS A BREEZE.

Each DPF cleans itself through regeneration. The DPF does require service cleaning at a minimum of 150,000-mile intervals for highway applications or approximately 4,500 hours for vocational applications. During service, the filter is removed, cleaned and reinstalled. The DPF is designed to last the life of the engine.